

# miniLED

# RGB

LED Colour Changers

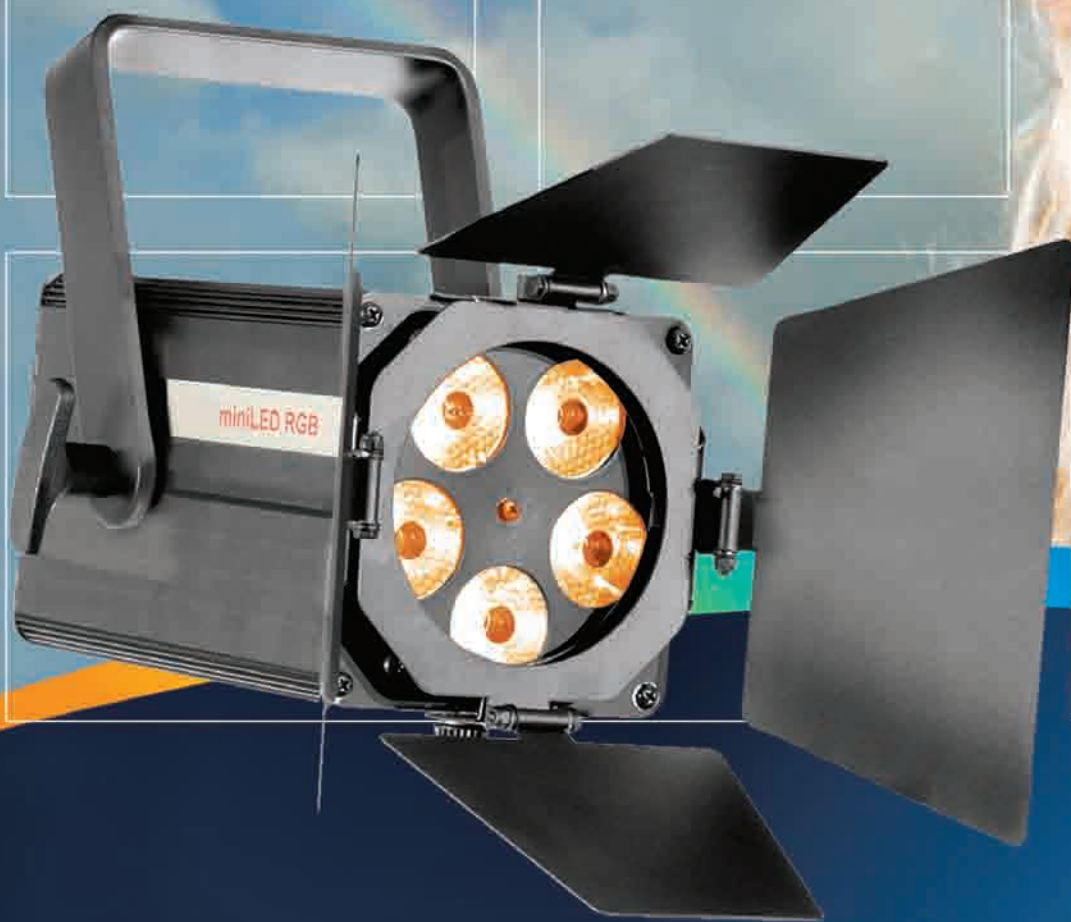

  
**SPOTLIGHT**  
professional lighting for the performing arts

**BODY DESIGN HARMONIZED  
WITH OTHER MINI FIXTURES**



**BRIGHT AND UNIFORM BEAM  
WITH VERY LOW HEAT PRODUCTION  
AND NO UV EMISSION**



# MINILED

LED Colour Changers

## Main Features

- Light source: matrix of five high power 3W leds with RGB colour mixing
- Powerful light beam with smooth distribution of light and colour
- Colour palette of up to 16.700.000 different hues
- Remote control via: DMX 512, manual, automatic, master/slave, Infra-Red Remote
- 3 channels for primary colours selection and electronic dimmer
- Programmable colour mixing effects and sequences
- Possibility of stand-alone operation without DMX signal Control
- 0-100% electronic dimmer control
- No UV emission
- No need for external power supply, direct from mains 230 V
- Very low energy consumption
- Suitable for general lighting and colour wash effects in a broad range of commercial installations, such as showrooms, exhibitions, hotels, bars, restaurants retail environments and shop windows
- The very long light source life (50000 hours) allows trouble-free installations even in locations where it would be difficult to reach the fixture for lamp replacement and maintenance.
- Compact and durable housing in extruded aluminium available in black and silver versions; other colours on request
- Accessories: Barndoor, Additional Prismatic Filter (for wider beam)

## Dimensions

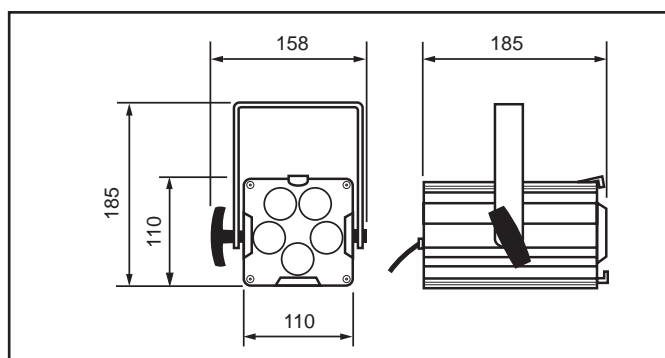

**OPTIONAL  
INFRARED  
REMOTE  
CONTROL**

